

Block Diagram

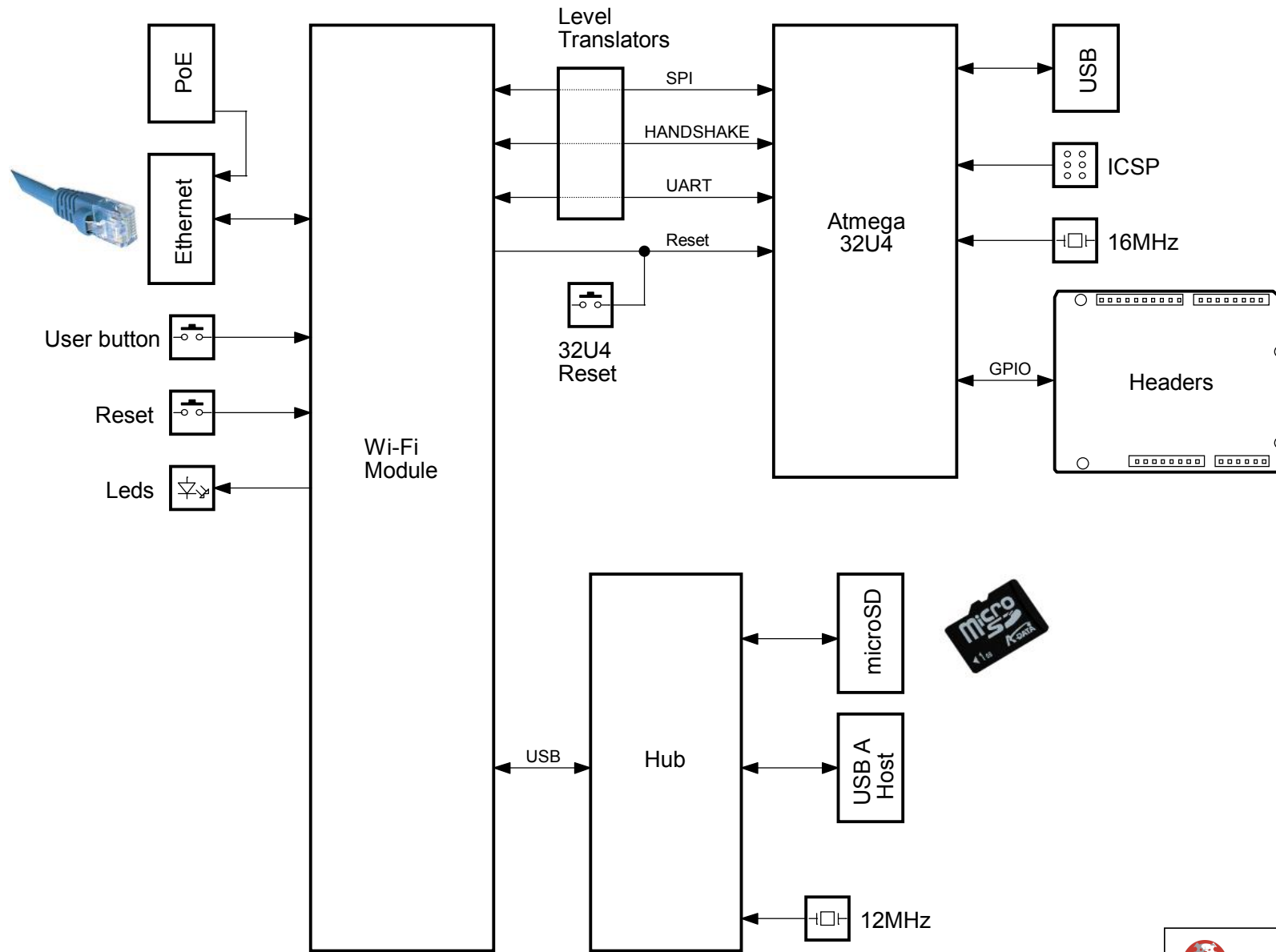

Wi-Fi & 32U4

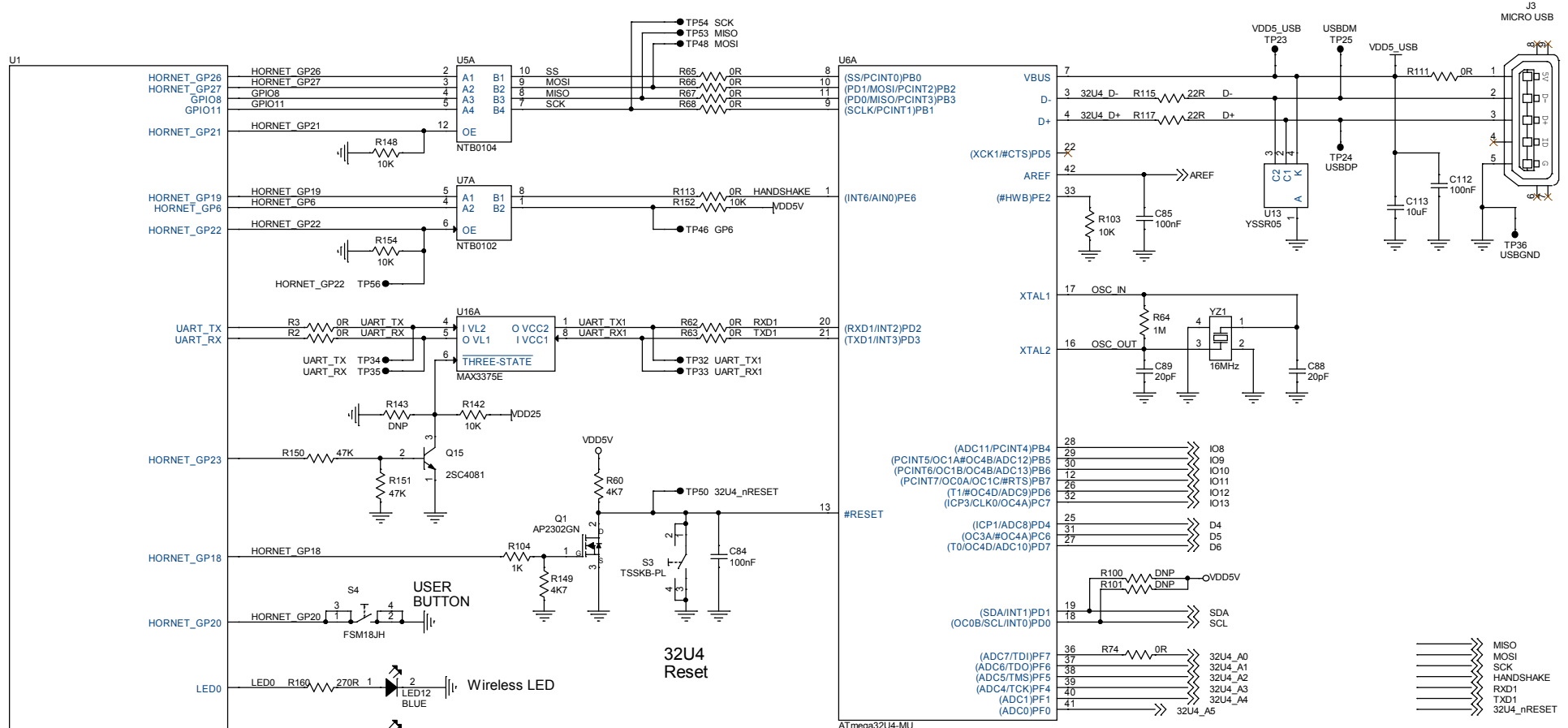

ATmega32U4-MU
Part 1 of 2

These files are licensed under a Creative Commons Attribution Share-Alike license, which allows for both personal and commercial derivative works, as long as they credit dog hunter LLC and release their designs under the same license. www.doghunter.org
The Linino software is also open-source. The source code is released under the GPL and the C/C++ microcontroller libraries are under the LGPL. www.linino.org

Wi-Fi Module

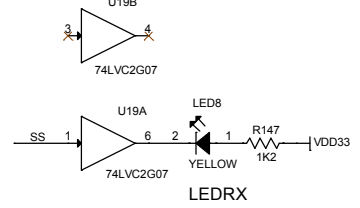
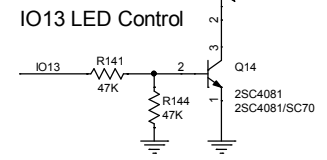

dog hunter

Title		Wi-Fi & 32U4	
Size	Document Number	Yun	Rev
A3			4
Date:	Thursday, January 15, 2015	Sheet	2 of 5

Hub, microSD & USB Host

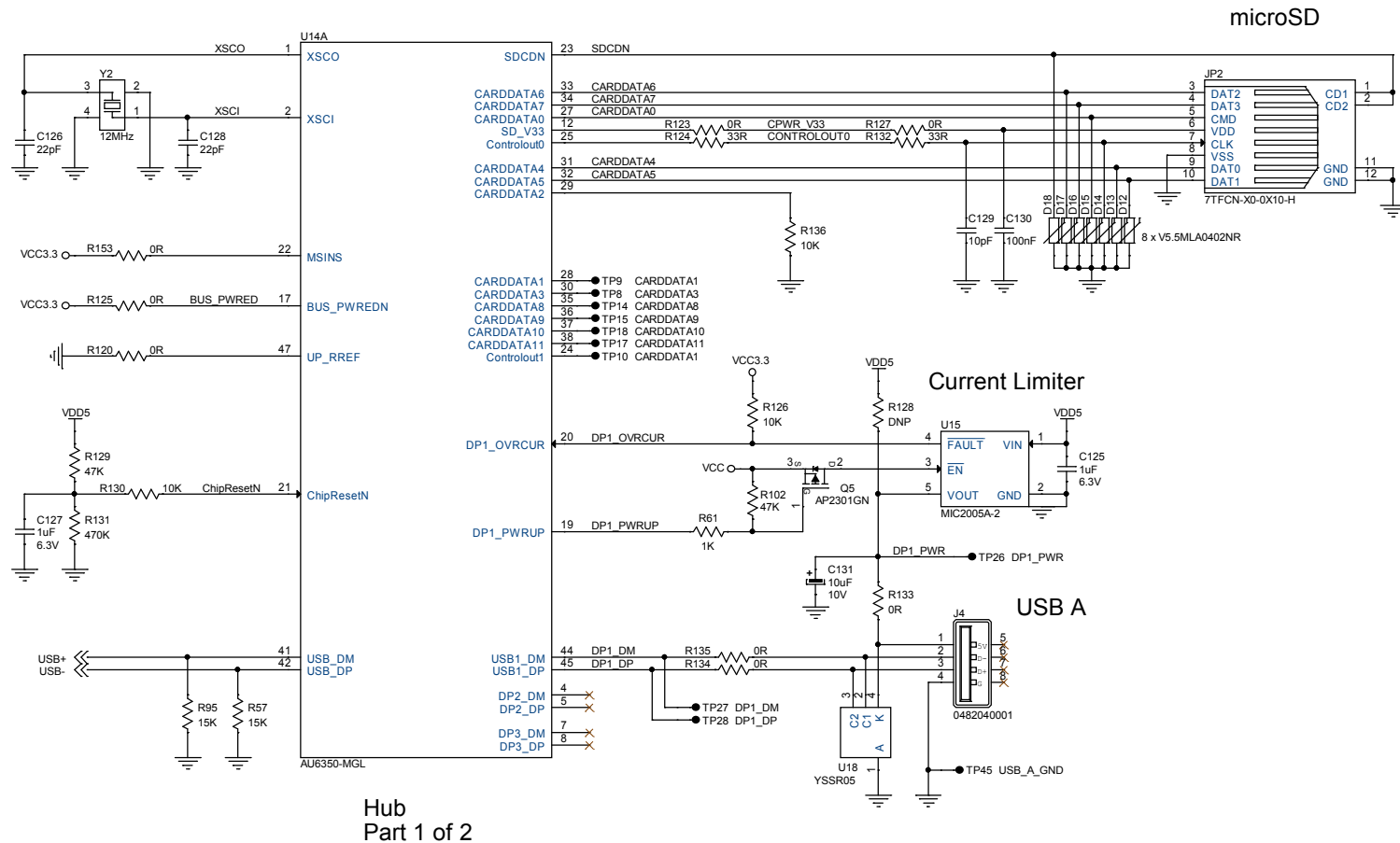



USB signal line trace:

1. Keep traces of USB bus D+ and D- the same length.
2. Achieve 90 ohm differential characteristic impedance.
3. Achieve 45 ohm common characteristic impedance.
4. Maintain parallelism between D+ and D-.
5. Do not route USB2.0 D+ and D- over the power plane split.
6. Do not route USB2.0 D+ and D- over the other high frequency signals.
7. It is preferred to route USB2.0 D+ and D- over ground layer.
8. It is preferred to route USB2.0 D+ and D- using single layer.

dog hunter

Title		
Hub, microSD & USB Host		
Size	Document Number	Rev
A3	Yun	4
Date: Thursday, January 15, 2015		
Sheet		of
3		5

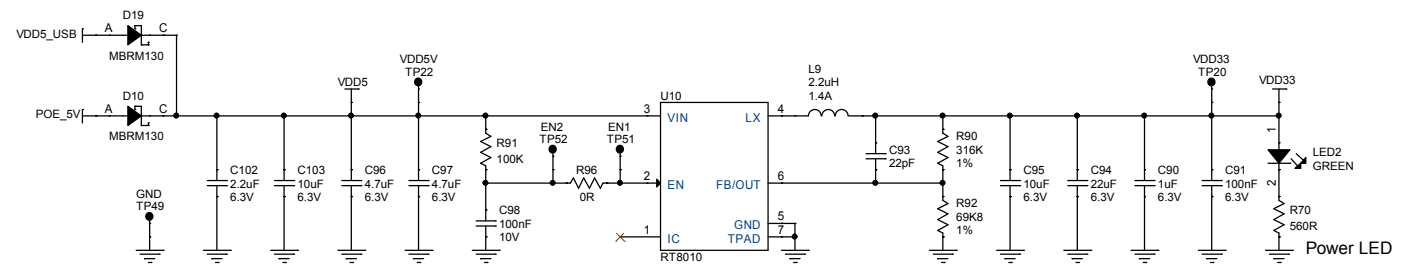
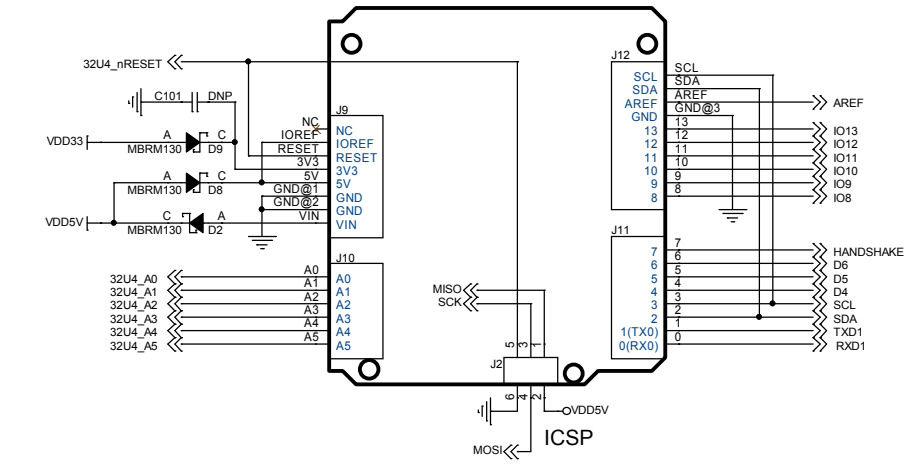
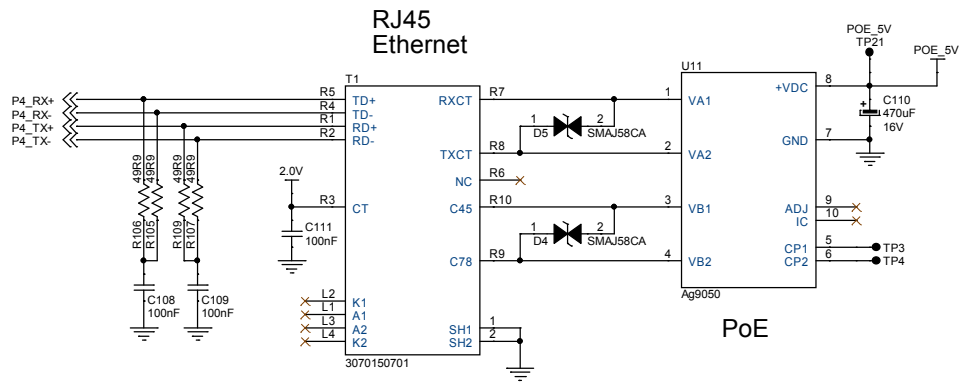
Power Supply & Pin Headers

dog hunter

Title		Power Supply & Pin Headers	
Size	Document Number	Yun	Rev 4
Date:	Thursday, January 15, 2015	Sheet	4 of 5

IC Power

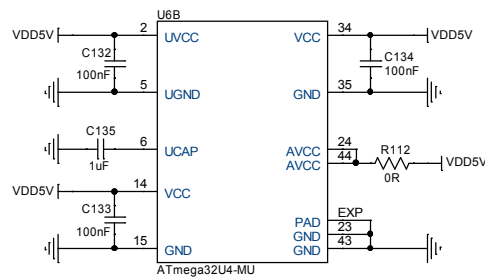

ATmega32U4
Part 2 of 2

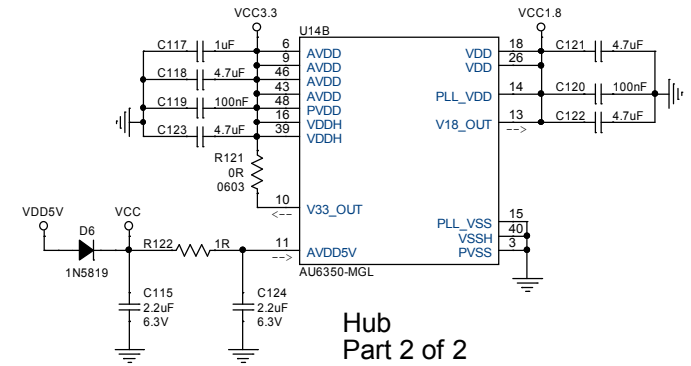
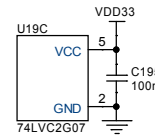
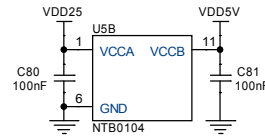
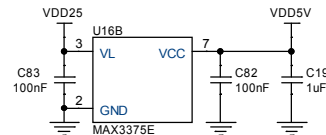
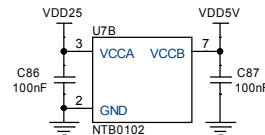

Hub
Part 2 of 2

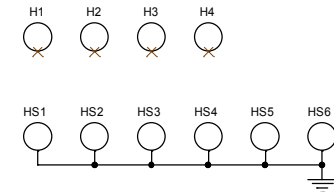

Reference Designs ARE PROVIDED "AS IS" AND "WITH ALL FAULTS". Arduino DISCLAIMS ALL OTHER WARRANTIES, EXPRESS OR IMPLIED, REGARDING PRODUCTS, INCLUDING BUT NOT LIMITED TO, ANY IMPLIED WARRANTIES OF MERCHANTABILITY OR FITNESS FOR A PARTICULAR PURPOSE. Arduino may make changes to specifications and product descriptions at any time, without notice. The Customer must not rely on the absence or characteristics of any features or instructions marked "reserved" or "undefined." Arduino reserves these for future definition and shall have no responsibility whatsoever for conflicts or incompatibilities arising from future changes to them. The product information on the Web Site or Materials is subject to change without notice. Do not finalize a design with this information. "Arduino" name and logo are trademarks registered by Arduino S.r.l. in Italy, in the European Union and in other countries of the world.

		
Title		
IC Power		
Size	Document Number	Rev
Custom	Yun	4
Date:	Thursday, January 15, 2015	Sheet 5 of 5